

CONVEYING EQUIPMENT

Conveying Systems
for Plastics Processing Plants

world of innovation



Feedmax S3 net

Single material loader

Wittmann

Optimized single loader for flexible conveying of smaller material volumes of up to 80 kg/h in permanent operation. Peak performance of up to 150 kg/h.

» **Robust stainless steel construction**

All components in contact with material are made of stainless steel and are therefore perfectly suited for critical and abrasive applications.

» **Polyester filter with blow-back cleaning**

To achieve a longer lifetime a polyester filter was used. The cloth-like filter surface is ensuring that any intake and accumulation of dust particles is made impossible. This filter is never losing its shape, and it is held in position during the entire conveying cycle, ensuring an absolutely unproblematic buildup of vacuum.

» **Wand**

Included in the standard package is a 780 mm long wand with air vents for the adjustment of the material load, as well as a 5 m PVC hose.

» **AmbiLED**

Light signal in different colors at the hinged lid for the visualization of internal operating conditions.

» **Granulator operating mode**

Adjustable timer function for the emptying of a granulator regrind bin depending on the fill level.

» **TeachBox plus (Option)**

Teach pendant for remote access when the loader is mounted on blenders or tall machine hoppers. Via the touch display, the control of up to 24 material loaders is possible.

» **Proportional valve (Option)**

The proportional valve for the conveying of two components is externally attached to the material inlet. The dosing relation can be set easily via a potentiometer.



Flap lid



Material inlet

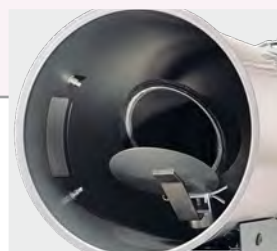

Material outlet

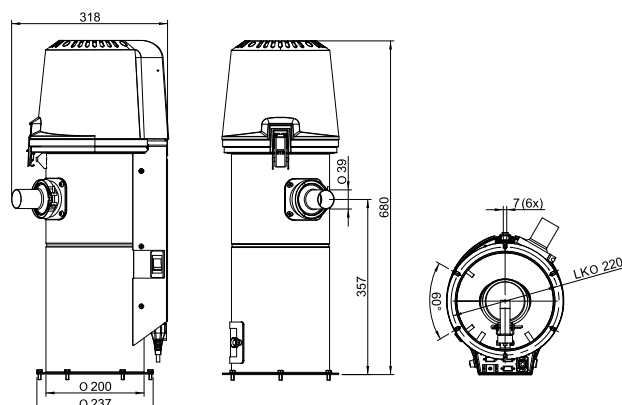

Feedmax basic/Feedmax plus

Central material loaders

These units combine the advantages of a single loader with those of central material loaders.

Feedmax basic is a practical, newly designed appliance with the appearance of a single loader, and has to be combined with high-performance blowers, so that it can reach a higher material throughput and handle material conveyance over longer distances.

Feedmax plus, based on the central loaders with pneumatic discharge shut-off valves, offers the possibility of controlling up to 24 devices using the **TeachBox basic** touch-screen remote control – even in combination with **Feedmax basic**.

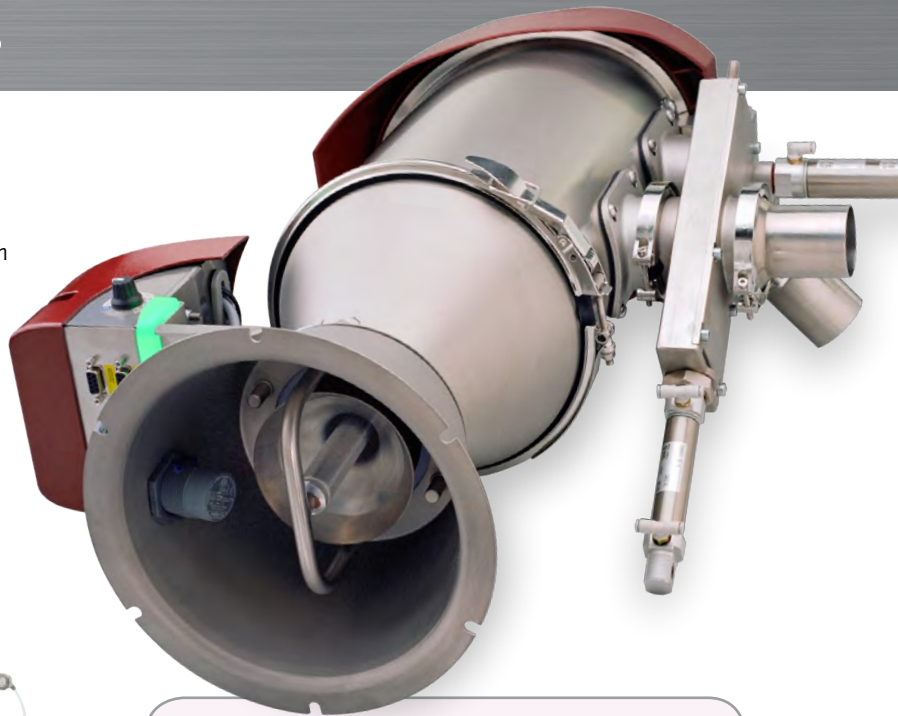

Feedmax basic

Feedmax plus

- » Material contacting components of stainless steel.
- » Vacuum connection with sealing surface.
- » Hinged lid with integrated screen.
- » Inlet with proper wall thickness, special steel precision casting.
- » **AmbiLED** status display.

Net5 system – TeachBox plus

The graphical surface of the **TeachBox plus** allows for the control of up to 24 conveying stations, up to two vacuum circuits. Beyond that, the control of filter stations and suction valves is possible.

Linked units are identified automatically. These units are displayed on a high-res 5.7" touch-screen: for simple operator guidance and process parameter display.

- » **Clearly arranged screen view**
Clear graphical display of units, including status display.
- » **Versatile setting possibilities**
Settings for conveying and vacuum can be easily changed (depending on the preset user rights).
- » **Display and administration of**
 - up to 24 **Feedmax S3 net**
 - up to 24 **Feedmax basic** or **Feedmax plus**
 - up to 2 vacuum lines and 1 back-up blower
 - up to 2 **Aton plus**



TeachBox plus

VS blower stations and central conveying

Wittmann

Blower/ pump model	Pump type	VS for station conveying	Power [kW]	max. Airflow [m ³ @50Hz] [cfm@50Hz]	max. Pressure [mbar@50Hz] [in.Hg@50Hz]
03	Side channel blower single stage	•	1.5	210 (123)	200 (5.9)
05	Side channel blower single stage	•	2.2	305	230
07	Side channel blower 2-stage	•	3	210 (123)	340 (10.0)
09	Side channel blower 2-stage	•	4.3	310 (182)	360 (10.6)
13	Side channel blower 2-stage	•	7.5	500 (294)	400 (11.8)
29	Claw pump	•	4.2	200 (117)	700 (20.6)
31	Claw pump	•	5	250 (147)	700 (20.6)
33	Claw pump	•	6	300 (176)	700 (20.6)



Central filter stations for VS

CS cyclone filter station

» 2-stage filtration system

In first stage pre-filtration takes place by means of the cyclone effect and in the second stage, micro filtration occurs by means of a polyester micro filter.

» Effective dust blow-off and user-friendliness

The filter surface is cleaned by means of implosion, and the dust is blown into a dust collection bag. For visual inspection, the dust container is executed in robust glass.

XMB Filter Station

» 2-stage filtration system

In first stage pre-filtration takes place by means of the cyclone effect and in the second stage, micro filtration occurs with a polyester micro-filter having 3 m² of surface area.

» User-friendly

The dust container can be removed during operation for emptying.

» Choice of dust container

The dust collection area is kept pressureless through a shut-off valve in the discharge cone of the filter and therefore allows the use of any dust collection container, e.g. a plastic bag.



Machine hopper for Feedmax

Machine hoppers ranging in size from 3 l to 60 l guarantee the optimum volume of the material inventory to the total material throughput and thus, the performance of the entire system.

» Stainless steel construction with sight glass

Sight glass for abrasive uses as well as visual control of the material flow.

» Assembly

Slotted holes in the flange allow easy attachment for various mounting hole patterns.

Applications



The modular design of the WITTMANN M8 hardware and software components and the arbitrary configuration enable the flexible realization of various special applications, like the equal load and automatic switchover between vacuum pumps, the controlled assignment of material sources to machines.

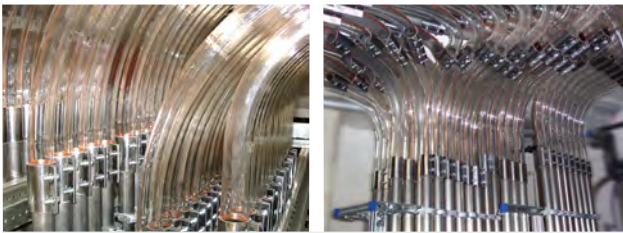

The use of high-quality installation material guarantees long life and trouble-free operation. The conveying of abrasive materials is accomplished preferably with glass elbows. The high performance Net5 system and M8 network controls are designed for highest durability. An important part of a highly reliable system is the professional and proper assembly of conveying tubes and connections. This includes the professional mounting of conveying tubes and connections.

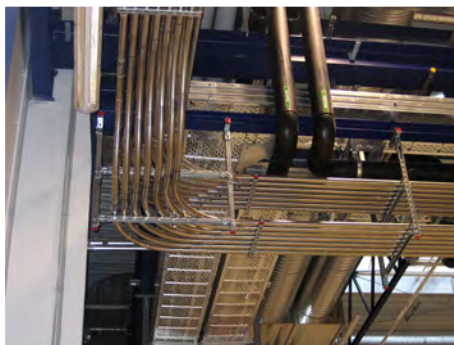

"No two central material handling systems are equal." - As varied as production facilities, so are the requirements on the central material handling system. Innovative product solutions are required more than ever before and can be achieved through the highly efficient WITTMANN controls.



"One-stop shopping." The extensive and innovative peripheral equipment program from WITTMANN allows the realization of demanding complete systems and the assignment of responsibility for the proper interaction of the single components. For service, a single phone call will cover the entire spectrum of WITTMANN products.

The Wittmann logo is a stylized, italicized wordmark in a dark red color, set within a white, rounded rectangular shape that has a slight shadow effect.

WITTMANN Technology GmbH

Lichtblaustrasse 10

1220 Vienna | Austria

Tel.: +43 1 250 39-0

info.at@wittmann-group.com

www.wittmann-group.com